

# Garrett® GTX5544R GEN II NEW PRODUCT

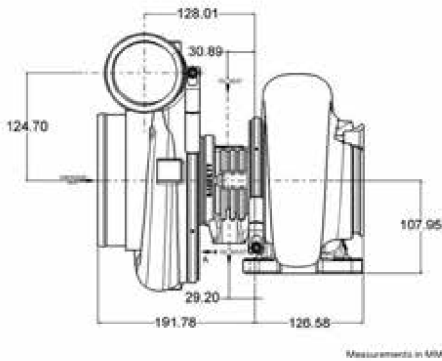

Horsepower: 1400- 2850  
Displacement: 3.0L - 12.0L



## COMPRESSOR MAP

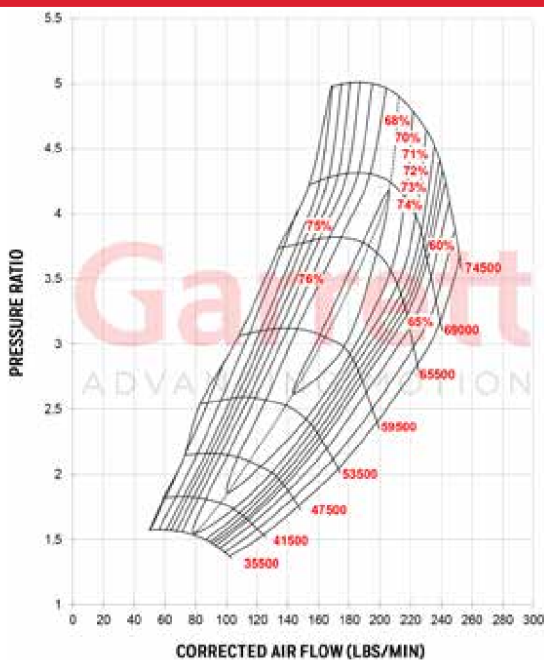

## FEATURES:

- ◆ GEN 2 COMPRESSOR WHEEL AERODYNAMICS
- ◆ LIGHTWEIGHT BILLET BACKPLATE
- ◆ (NEW) BACKPLATE TO COMPRESSOR HOUSING O-RING
- ◆ 144MM COMPRESSOR EXDUCER
- ◆ FEATURES THE .96 A/R COMPRESSOR HOUSING
- ◆ SUPER CORE AND TURBINE HOUSING SOLD SEPARATELY
- ◆ COMPATIBLE WITH GT, GTX, AND GTX5533R TURBINE HOUSINGS

## EXHAUST FLOW CHART

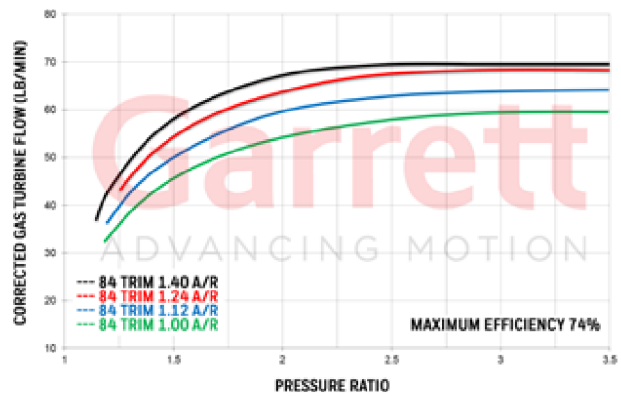

GTX5544R Gen II Reference Data		Compressor				Turbine		
Super Core PN	Inducer	Exducer	Trim	A/R	Inducer	Exducer	Trim	
851285-5021S	102mm	144mm	50	0.96	112	102	84	
851285-5022S	106mm	144mm	54	0.96	112	102	84	
Notes:		Turbine Kit PN	A/R	Inlet	Outlet	Wastegate	Divided	Trim
Super Core and Turbine Kit Sold Separately	<span style="border: 1px solid black; padding: 2px;">NEW PRODUCT</span>	761208-0062	1.24	V-Band	V-Band	Free Float	N	84
	<span style="border: 1px solid black; padding: 2px;">NEW PRODUCT</span>	761208-0063	1.40	V-Band	V-Band	Free Float	N	84
		761208-0014	1.00	T6	V-Band	Free Float	N	84
		761208-0015	1.12	T6	V-Band	Free Float	N	84
		761208-0025	1.24	T6	V-Band	Free Float	N	84
* SFI Certified Turbine Housings	<span style="border: 1px solid black; padding: 2px;">NEW PRODUCT</span>	761208-0017	1.40	T6	V-Band	Free Float	N	84
	<span style="border: 1px solid black; padding: 2px;">NEW PRODUCT</span>	761208-0054	1.24	V-Band	V-Band	Free Float	N	84
	<span style="border: 1px solid black; padding: 2px;">NEW PRODUCT</span>	761208-0055	1.40	V-Band	V-Band	Free Float	N	84
	<span style="border: 1px solid black; padding: 2px;">NEW PRODUCT</span>	761208-0026	1.00	T6	V-Band	Free Float	N	84
		761208-0027	1.24	T6	V-Band	Free Float	N	84